

WARD: Ashley CONTACT OFFICER: Angelo Calabrese
SITE ADDRESS: 9 Minto Road Bristol BS2 9YB

APPLICATION NO: 13/05241/F Full Planning
EXPIRY DATE: 7 January 2014

Change of use from industrial unit into single family dwelling. Associated external alterations to include alterations to roof form and insertion of dormer windows and rooflights in rear and side roof slopes.

RECOMMENDATION: Grant subject to Condition(s)

AGENT: Redeem
3 Haycombe
Whitchurch
Bristol
BS14 0AJ
APPLICANT: Mr A Ashrif
105 Mina Road
St Werburghs
Bristol

The following plan is for illustrative purposes only, and cannot be guaranteed to be up to date.

LOCATION PLAN:

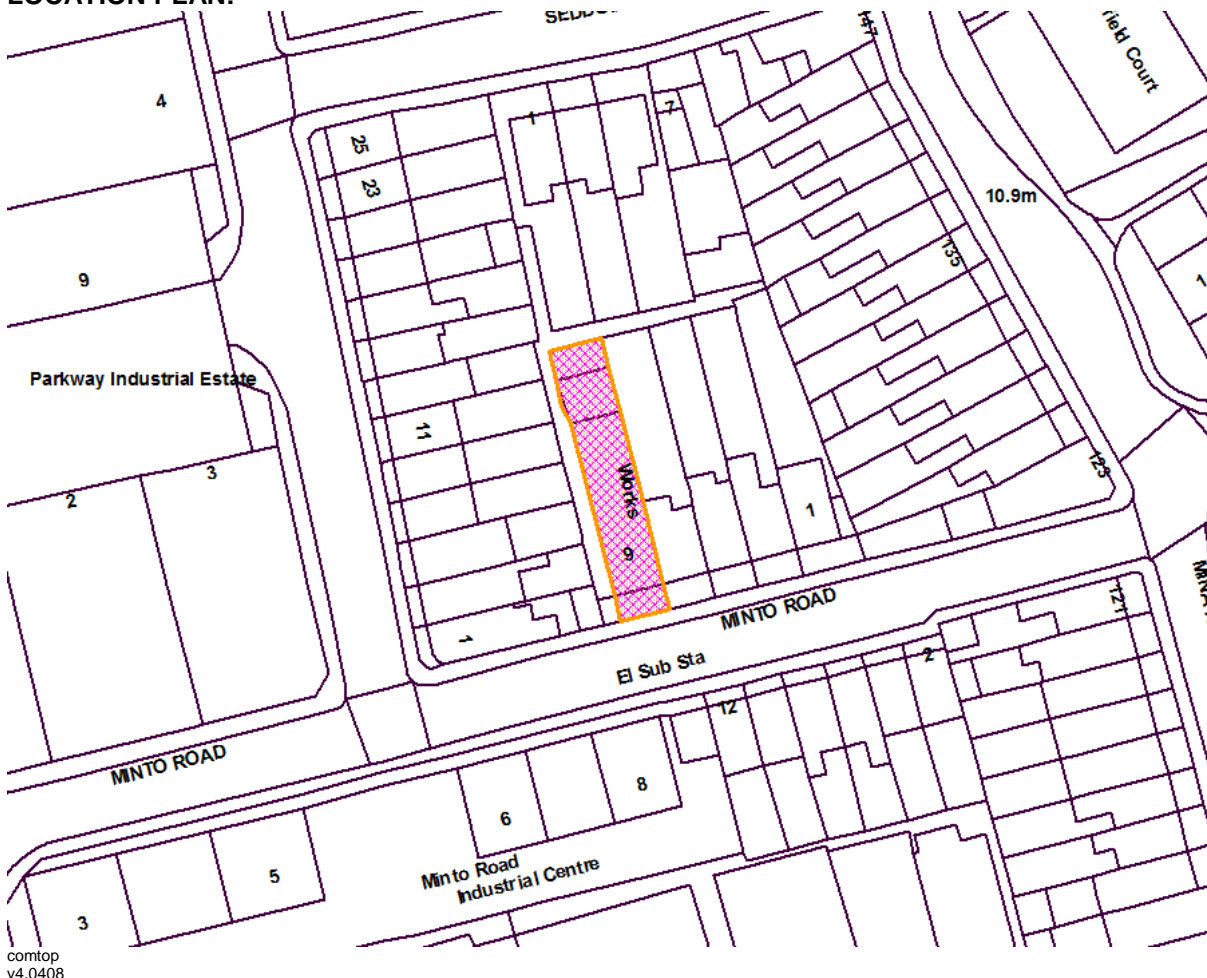

comtop
v4.0408

Development Control Committee A – 30 July 2014
Application No. 13/05241/F: 9 Minto Road Bristol BS2 9YB

SITE DESCRIPTION

The application site is an industrial unit located on the north side of Minto Road in St Werburgh's. The building is surrounded by two storey residential properties. The building has previously been used as a candle workshop, electrical motor repairs, and a window and kitchen manufacturer.

RELEVANT HISTORY

08/03140/F: Application for Change of use from industrial unit into single family dwelling. Associated external alterations to include raising level of pitched roof and insertion of dormer windows and rooflights in side roof slopes. Refused permission for the following reasons:

1. The unjustified loss of existing employment floor space is not acceptable as it has not been demonstrated that the floor space to be lost meets any of the exception criteria outlined in the Joint Structure Plan Policy 30 and Local Plan Policy EC4. The proposal would therefore have an unacceptable impact on the economy of the local area and the city as a whole. The proposal is therefore contrary to Structure Plan Policy 30, Local Plan Policy EC4 of the Adopted Local Plan (1997), Local Plan Policy EC4A of the First Deposit Draft of the Local Plan (2003), and SPD6 Economic Contributions from New Development (2005).
2. The introduction of the proposed rooflights and dormer windows within the two side roof slopes will enable direct overlooking of adjoining land and buildings from habitable rooms proposed in the roofspace, with the resultant loss of privacy contrary to Local Plan Policy B8 of the Adopted Local Plan (1997).
3. The proposed alterations to the front of the building detract from the character and form of the building and harm the street scene contrary to Local Plan Policy B1 of the Adopted Local Plan (1997).

11/02780/F: Application for Change of use from industrial unit into single family dwelling. Associated external alterations to include raising level of pitched roof and insertion of dormer windows and rooflights in side roof slopes. Withdrawn due to officer concerns with the loss of employment floorspace and the alterations to the front elevation.

11/04444/F: Application for Change of use from industrial unit into single family dwelling. Associated external alterations to include raising level of pitched roof and insertion of dormer windows and rooflights in side roof slopes. Granted permission on the 09.02.2012.

13/00340/F: Application for Change of use from industrial unit to single family dwelling. Associated external alterations to include raising level of pitched roof and insertion of dormer windows and rooflights. Refused consent for the following reasons:

1. The proposed first floor windows and balcony and their position relative to that of the adjoining properties, would result in an unacceptable level of overlooking, in particular to numbers 5 to 11 St Werburghs Road, with a consequent loss of privacy. This would be contrary to policy BCS21 of the adopted Bristol Development Framework Core Strategy (June 2011).
2. The proposed roof extensions by reason of their size and form would appear unduly prominent and visually jarring, and be out of character with the type of roofscape in the area, and thus be detrimental to the visual amenity of the area. This would be contrary to saved policy B2 of the Bristol Local Plan (December 1997) and policy BCS21 of the adopted Bristol Development Framework Core Strategy (June 2011).

Development Control Committee A – 30 July 2014
Application No. 13/05241/F: 9 Minto Road Bristol BS2 9YB

3. The proposal fails to demonstrate how it would mitigate its own impact on climate change in terms of minimising energy requirements or establish whether the incorporation of the site renewables and low carbon energy development is achievable. The proposal is therefore contrary to Policies BCS13, BCS14 and BCS15 of the Bristol Development Framework Core Strategy (June 2011).

Case officer note: The applicant has commenced work on site and has constructed a new roof and made alterations to the west elevation. The works on site are not in accordance with the approved planning application 11/04444/F.

As the works are not in accordance with any approved planning application, the works are currently unauthorised.

APPLICATION

The application proposes to change the use of the building from commercial to a residential dwelling. A mansard roof extension is proposed with a lift shaft. The roof will also have dormer windows to the front and rear. Alterations are proposed to the side elevation facing the rear elevations of St Werburgh's Road properties, which will include new windows at ground and first floor. A long near full height window will be installed to serve the new hallway on the west elevation. The plans state that all first floor windows will be obscure glazed.

Solar panels are shown on the west roof slope (the addendum to the sustainability statement received on 30th June, also states that panels will also be installed on the east slope).

The alterations to the front elevation include a new door in the existing opening and new window for the lounge.

The application includes a lift shaft to provide access to the first and second floor. The second floor (in the roof) will be a play area. It is noted that the applicant is developing this property to provide appropriate accommodation for his disabled son.

Accuracy of drawings

It should be noted that there are issues with the accuracy of the drawings. The planning department have requested accurate drawings since registration of the application to ensure that an assessment can be made of the impact of what has been constructed on site. The planning department are currently dealing with a complaint from neighbouring residents regarding the assessment of the previous planning applications and one of the issues is that the previous application did not have accurate drawings.

The case officer has spent a considerable amount of time requesting that the applicants architect provide accurate drawings of what is being built on site. The latest revision is considered to be an accurate drawing of the works to the roof, but there is still an issue with the accuracy of the existing elevations.

The applicant is unable to provide accurate drawings of the building showing the size of the original pitched roof because the original roof form has already been altered. While we do not have accurate drawings of the existing elevations, it is considered that an adequate assessment of the impact of the development can be made as the frame of the proposed roof has been constructed and officers have visited the development, and viewed it from one of the neighbouring properties to assess this impact. It is not considered that existing elevations would aid this assessment in any greater detail, as the impact can be assessed on site.

Development Control Committee A – 30 July 2014
Application No. 13/05241/F: 9 Minto Road Bristol BS2 9YB

RESPONSE TO PUBLICITY AND CONSULTATION

Neighbouring properties have been consulted on two separate occasions, when the application was originally submitted and when revised plans were received.

A total of 7 representations were received to both periods of consultation. Of the 7 comments, 1 was a general comment and 1 comment was in support, with the remainder being objections. The comment in support was from the applicant who responded to comments made by the objectors. (This has not been included in the following synopsis of issues raised)

The following planning issues were raised:

Principle (key issue A)

The application does not include an economic statement.

Design (Key issue B)

Negative impact on design and character of the area:

The attractive Victorian window openings have been demolished and replaced with larger concrete block openings suggesting the building will be rendered.

Impact on residential amenity (Key issue C):

The applicant has built a bulkier mansard roof than what was previously approved.

Do not find acceptable a three storey rendered/concrete block dwelling that may never be completed.

Solar panels to the roof would cause harmful glare to neighbouring properties.

Overlooking from first floor side windows without obscure glazing.

Overlooking from first floor and roof dormer to rear elevation of neighbouring buildings.

Loss of light to neighbouring properties due to increase in roof height

Inaccurate existing elevation drawings.

Other issues (not planning issues):

No attention is being had to on-site safety.

Ward Members

The application was previously called in by Councillors Telford and Hoyt, but they then withdrew the referral.

OTHER COMMENTS

Contaminated Land Environmental Protection has commented as follows:-

No objection subject to condition.

Development Control Committee A – 30 July 2014
Application No. 13/05241/F: 9 Minto Road Bristol BS2 9YB

RELEVANT POLICIES

National Planning Policy Framework – March 2012

Bristol Local Plan, Adopted December 1997

B2	Local Context
B6	Building Exteriors and Elevations
M1	Transport Development Control Criteria
EC4	Protection: Existing Employment Opportunities

Bristol Core Strategy (Adopted June 2011)

BCS8	Delivering a Thriving Economy
BCS10	Transport and Access Improvements
BCS13	Climate Change
BCS5	Housing Provision
BCS14	Sustainable Energy
BCS15	Sustainable Design and Construction
BCS16	Flood Risk and Water Management
BCS18	Housing Type
BCS20	Effective and Efficient Use of Land
BCS21	Quality Urban Design

Bristol Site Allocations and Development Management Policies (emerging)

DM1	Presumption in favour of sustainable development
DM12	Retaining valuable employment sites
DM23	Transport development management
DM26	Local character and distinctiveness
DM27	Layout and form
DM30	Alterations to existing buildings
DM32	Recycling and refuse provision in new development
DM34	Contaminated land

KEY ISSUES

(A) IS THE CHANGE OF USE ACCEPTABLE IN PRINCIPLE?

Policy BCS8 requires the retention of employment land where it makes a valuable contribution to the economy and employment opportunities.

DM12 of the Site Allocations and Draft Development Management document 2013 states that employment sites will be retained unless it is demonstrated that there is (i) no demand for the floorspace, (ii) continued employment use would have an unacceptable impact on the surrounding area, (iii) a new reduction in floorspace is necessary to improve the exiting premises, (iv) or the proposal is for commercial training purposes.

The conclusion made in the assessment of the application 11/04444/F was that the building was not considered important to the supply of floorspace in the area, or that there was any demand for the building. It was also noted at the time that the change of use from commercial to residential would be more appropriate in this residential context, where there are houses surrounding the application site. It is not considered necessary to require an economic statement for the application as the principle has been established under the previous permission. In response to the objection made on the grounds that an economic statement should be submitted, a request was made to the applicant to submit a statement, but the applicant replied that one was not necessary due to the previous approval.

Development Control Committee A – 30 July 2014
Application No. 13/05241/F: 9 Minto Road Bristol BS2 9YB

The loss of employment floorspace is not considered to be contrary to the requirements of BCS8 or DM12 and residential use would be a more appropriate use of the site. The proposed development is, therefore, acceptable in principle.

(B) WOULD THE PROPOSED DEVELOPMENT HARM THE CHARACTER OR APPEARANCE OF THE AREA?

Policy BCS21 of the Core Strategy requires development to contribute positively to an area's character and identity, creating or reinforcing local distinctiveness. Policies DM26, DM27, DM30 of the Site Allocations and Draft Development Management document 2013, is a set of design polices which require development to respect scale, form, proportion, material, and overall design of the host building.

Compared to the 2011 permission the proposed roof extension is 400mm taller than the approved scheme, and 1m wider. The proposed dormer windows on the rear and front elevation are also substantially larger than what was previously approved. The approved dormers had a size of approx. 1.32 sqm. The as built dormers are approx. 4sqm each.

It is clear on plan, that the roof as built appears bulkier and larger than what was previously approved and also the previous refused application 13/00340/F (the proposed lift shaft has been reduced in size from the previously refused application).

On plan the appearance of the new roof appears slightly awkward and does not appear to sit comfortably on the building, but it is not considered that the visual impact when viewed on the street is as significant as the drawings suggest. When viewed from the street the roof appears as a pitched roof with a flat section on top and the overall impact on the street scene is not significant.

While a mansard roof is not typical of the street, the proposed roof would, on balance, have an acceptable visual impact on the area.

A number of objections have been made to the use of render on the side elevation of the property which will replace the existing brick elevation. The concerns are that the render would result in the loss of an attractive red brick wall to the property. The use of render on the side elevation would be acceptable. There are other properties in the area which have rendered elevations, and therefore it is not considered that render would have a harmful impact on the appearance of the property. Render is needed to provide a consistent material, due to the filling in of original openings with block work.

While a mansard roof is not typical of the area the appearance of the roof as built is not considered to have a significant visual impact on the area to warrant a refusal of planning permission.

(C) WOULD THE PROPOSAL UNACCEPTABLY AFFECT THE RESIDENTIAL AMENITY OF NEIGHBOURING PROPERTIES?

Policy BCS21 of the Core Strategy and DM30 of the Site Allocations and Draft Development Management document 2013 requires development to safeguard the amenity of neighbouring properties.

Impact from roof structure

The proposal result in an increase in height to the roof of the building which is approximately 2m away from the boundary of the gardens to properties on St Werburgh's Road. A site visit was carried out to a neighbouring property by the case officer to assess the impact on the properties in St Werburghs Road.

Development Control Committee A – 30 July 2014
Application No. 13/05241/F: 9 Minto Road Bristol BS2 9YB

It is clear that the as-built roof is larger than the original pitched roof to the building. While there are issues with the accuracy of the existing elevations submitted, the impact of the larger roof can be assessed on the basis of what has been built on site.

It is acknowledged that there is an increase in height and that the alteration to the shape of the roof would have some harmful impact on the outlook from both the rear garden and the windows in the rear elevation. However the shape of the roof is such that it slopes back away from the boundary and would therefore not obliterate views of the sky around the building, which in turn reduces the overbearing impact of the roof. It is considered that the main oppressive impact of the building on these gardens and neighboring windows is from the existing large flank wall.

It is considered that the changes to the roof would not have a significant impact on light into the ground floor or upper floors of neighbouring properties.

The new roof clearly has a harmful impact but, on balance it is not considered that the proposed change to the existing tight relationship between the existing building and neighbouring residential properties is significant enough to warrant a refusal on residential amenity.

Overlooking

The building as originally built had 10 windows at first floor level which allows direct overlooking to neighbouring gardens and rear windows of neighbouring properties. The proposal seeks consent to insert new windows in the side elevation. The plans state that all of the proposed first floor windows will be obscure glazed. If permission is granted a planning condition will be attached to the decision which will require these windows to be obscure glazed and fixed shut. This will ensure that there is no unacceptable overlooking to neighbouring properties. The windows on the ground floor are below boundary wall level and therefore will not require obscure glazing.

One resident has expressed concerns with overlooking from the proposed rear first floor window and dormer into 13 St Werburgh's Road. The position of these windows at a right angle to the boundary of this property is such that the overlooking would not be significant to warrant refusal.

The rear windows are also over 25m to the nearest windows on properties to the north on Seddon Road and therefore would not have an unacceptable relationship with these properties.

Light pollution

Concerns have been raised on the previous application of the potential impact from lights within the new residential property and the impact on neighbouring dwellings. While there would be some impact from lights being on, the impact from a room light would not be significantly glaring to result in a significant impact.

Solar panels

An objection has been made to the potential impact of glare from solar panels. Solar panels in their nature should absorb as much light as possible so that they are efficient. There may be some reflection, similar to reflection from roof lights, but it is considered that the impact would not be significantly harmful to amenity.

To conclude it is acknowledged that the new roof would have some harmful impact on neighbouring properties, but on balance, the impact would not be significant to warrant a refusal. The use of the building for residential purposes would be a significant improvement over the lawful use of the site for industrial purposes. Subject to conditions the development would not significantly harm the amenity of neighbouring properties.

Development Control Committee A – 30 July 2014
Application No. 13/05241/F: 9 Minto Road Bristol BS2 9YB

(D) WOULD THE PROPOSED DEVELOPMENT SATISFACTORILY ADDRESS TRANSPORT AND MOVEMENT ISSUES?

Policies BCS10 and DM23 require developments to address highway safety and sustainable transport.

The application does not provide any off street parking and given the lawful industrial use of the property, it is considered that the development does not require any. The development of one further dwelling would not increase traffic or congestion in the area significantly.

The highway officers have previously advised that the existing dropped kerb should be reinstated and that a small boundary wall should be erected to the road frontage to resist parking within the front garden area as there is insufficient space for a vehicle to park in this area without overhanging the highway. To ensure this a condition will be attached to the permission for details of a small boundary wall which will have to be constructed before occupation of the building.

Cycle parking is shown on the plans, but will have to be made larger for 3 cycles as required under the new parking standards within the Draft Development Management Policies. This will be secured by a planning condition.

Subject to conditions the development would not raise any highway safety issues.

(E) DOES THE DELVEOPMENT PROVIDE SUITABLE ACCOMODATION FOR FUTURE OCCUPIERS?

Policy BCS18 of the Core Strategy requires development to provide sufficient space for everyday activities and to enable flexibility and adaptability by meeting appropriate space standards.

The development provides a suitable standard of accommodation for future occupiers. There are two rooms on the first floor which would have windows that are obscure glazed, but all other rooms have a clear outlook. It is also noted that the property is being designed to provide suitable accommodation for the applicant's disabled child.

Therefore, it is considered that the development would provide suitable living accommodation for future occupiers.

(F) ARE THERE ANY GROUND CONTAMINATION ISSUES?

The Ground contamination officer has reviewed the application and has raised no issues subject to confirmation of the approach to the works in the garden, which should be either importation of soils to create a barrier to any contamination or a hardstanding area with a geotextile membrane underneath to act as a warning layer for future occupiers of the building.

Subject to conditions there are no significant ground contamination issues.

(G) DOES THE DEVELOPMENT COMPLY WITH THE CLIMATE CHANGE AND SUSTAINABILITY POLICIES OF THE CORE STRATEGY?

Policies BCS13-BCS16 requires development to have regard to mitigating climate change, reducing energy use and incorporate water management measures.

The previous planning application was refused on the lack of information to demonstrate that the development would minimize energy requirements or establish whether the incorporation of on-site renewables is achievable.

Development Control Committee A – 30 July 2014
Application No. 13/05241/F: 9 Minto Road Bristol BS2 9YB

The development includes a short sustainability statement which states that solar panels on the roof of the development would achieve a 20% saving on residual energy use as required under policy BCS14 of the Core Strategy. The document also advises how the development will comply with latest Building Regulations in terms of energy efficiency, thermal insulation and water consumption.

The report as submitted included limited information in relation to the energy saving of the solar panels, therefore a request was made for further clarification of the figures provided.

An updated report was submitted on the 30th June which states that solar panels can be installed on the west and east facing roof slopes to provide an energy saving. Unfortunately the report as written appears to have incorrect figures as it suggests that the regulated CO2 emissions would increase after the installation of the solar panels. This cannot be correct as the installation of on-site renewables would normally reduce the CO2 emissions of a building. Clarification on the figures is now being sought, but it should be noted that Planning Inspectors at appeal have conditioned the requirement for sustainability statements post decision, so it is not considered reasonable to refuse the application on this specific matter.

CONCLUSION

The principle of the change of use was considered acceptable in 2011 and there is no change to that position, and a residential use would have a better relationship with neighbouring properties than an industrial use. The physical alterations to the building would not have a negative impact on the character of the area.

While the new roof is considered to have some harmful impact on neighbouring properties, the impact, on balance, is not considered significant to warrant a refusal. Subject to conditions the proposal would also not result in significant overlooking to neighbouring properties.

The proposal is considered to be satisfactory for all other planning issues and is recommended for approval.

COMMUNITY INFRASTRUCTURE LEVY

How much Community Infrastructure Levy (CIL) will this development be required to pay?

The CIL liability for this development is £16,822.

RECOMMENDED GRANT subject to condition(s)

Pre commencement condition(s)

1. Further details of the following before relevant element started

Detailed drawings of the following shall be submitted to and be approved in writing by the Local Planning Authority before the relevant part of work is begun. The detail thereby approved shall be carried out in accordance with that approval.

- a) Timber barn doors
- b) Small front boundary wall to match neighbouring properties
- c) Cycle store (the store shown on the plans is too small to accommodate cycle storage. This store shall be enlarged in size to accommodate 3 cycles)
- d) Roof plans showing all solar panels and method of fixing to roof

Development Control Committee A – 30 July 2014
Application No. 13/05241/F: 9 Minto Road Bristol BS2 9YB

The front boundary wall shall be erected prior to occupation of the building and maintained thereafter.

The approved cycle storage shall be installed before occupation of the building and retained for the use of cycles thereafter.

The approved solar panels shall be installed before the occupation of the building and retained thereafter.

Reason: In the interests of visual amenity, the character of the area and highway safety.

2. Submissions of samples before specified elements started

Samples of the render, shall be submitted to and be approved in writing by the Local Planning Authority before the relevant parts of the work are commenced. The development shall be completed in accordance with the approved samples before the building is occupied.

Reason: In order that the external appearance of the building is satisfactory.

Pre occupation condition(s)

3. Prior to the proposed laying of the grassed and patio area to the rear of the property, the applicant shall confirm in writing that they will provide the following:

- 1) A clean cover system in the back garden of at least 400mm subsoil and topsoil to create a barrier to any contamination that resides within the site soils. All imported topsoil should meet the criteria in advice attached to this notice.
- 2) Proposed patio area shall have a high visibility geotextile membrane underneath to act as a warning layer for any future occupiers of the building.

The development shall be carried out in accordance with the confirmed details.

Reason: To ensure that risks from land contamination to the future users of the land and neighbouring land are minimised.

4. Implementation/installation of refuse storage and recycling facilities - shown on approved plans

No building or use hereby permitted shall be occupied or the use commenced until the refuse store, and area/facilities allocated for storing of recyclable materials, as shown on the approved plans have been completed in accordance with the approved plans. Thereafter, all refuse and recyclable materials associated with the development shall either be stored within this dedicated store/area, as shown on the approved plans, or internally within the building(s) that form part of the application site. No refuse or recycling material shall be stored or placed for collection on the public highway or pavement, except on the day of collection.

Reason: To safeguard the amenity of the occupiers of adjoining premises, protect the general environment, and prevent obstruction to pedestrian movement, and to ensure that there are adequate facilities for the storage and recycling of recoverable materials.

Development Control Committee A – 30 July 2014
Application No. 13/05241/F: 9 Minto Road Bristol BS2 9YB

Post occupation management

5. No Further Windows

Notwithstanding the provisions of the Town and Country Planning (General Permitted Development) Order 1995 (or any Order revoking and/or re-enacting that Order) no windows, other than those shown on the approved plans shall at any time be placed in any elevation of the building hereby permitted without the grant of a separate planning permission from the Local Planning Authority.

Reason: To safeguard the amenities of the adjoining premises from overlooking and loss of privacy.

6. No further extensions

Notwithstanding the provisions of the Town and Country Planning (General Permitted Development) Order 1995 (or any Order revoking and/or re-enacting that Order) no extension or enlargement (including additions to roofs) shall be made to the dwellinghouse(s) hereby permitted, or any detached building erected, without the express permission in writing of the council.

Reason: The further extension of this (these) dwelling(s) or erection of detached building requires detailed consideration to safeguard the amenities of the surrounding area.

7. Non opening and obscured glazed window

Notwithstanding the provisions of the Town and Country Planning (General Permitted Development) Order 1995 (or any Order revoking and/or re-enacting that Order) the proposed first floor side elevations windows and fall height hallway window, facing St Werburgh's Road shall be non-opening and glazed with obscure glass to a specification to be agreed with the Local Planning Authority and shall be permanently maintained thereafter as non-opening and obscure glazed.

Reason: To safeguard the amenities of the adjoining premises from overlooking and loss of privacy.

List of approved plans

8. List of approved plans and drawings

The development shall conform in all aspects with the plans and details shown in the application as listed below, unless variations are agreed by the Local Planning Authority in order to discharge other conditions attached to this decision.

R112/01D Existing Ground and First Floor Plan and Front Elevation, received 25 April 2014

R112/02E Existing Side and Rear Elevations, received 25 April 2014

R112/03F Proposed Ground, First and Second Floor Plans, received 24 April 2014

R112/04K Proposed Side Elevations, received 13 June 2014

R112/05I Site Location Plan, Proposed Front and Rear Elevations, received 25 April 2014

R112/06F Existing and Proposed Block Plan, received 25 April 2014

R112/07C Section drawing showing relationship with St Werburgh's Road, received 25 April 2014

Reason: For the avoidance of doubt.

Development Control Committee A – 30 July 2014
Application No. 13/05241/F: 9 Minto Road Bristol BS2 9YB

BACKGROUND PAPERS

Contaminated Land Environmental Protection

16 July 2014



Relationship with St Werburgh's Road 2014



Application site in 2011, Minto Road



Application site 2014, Minto Road



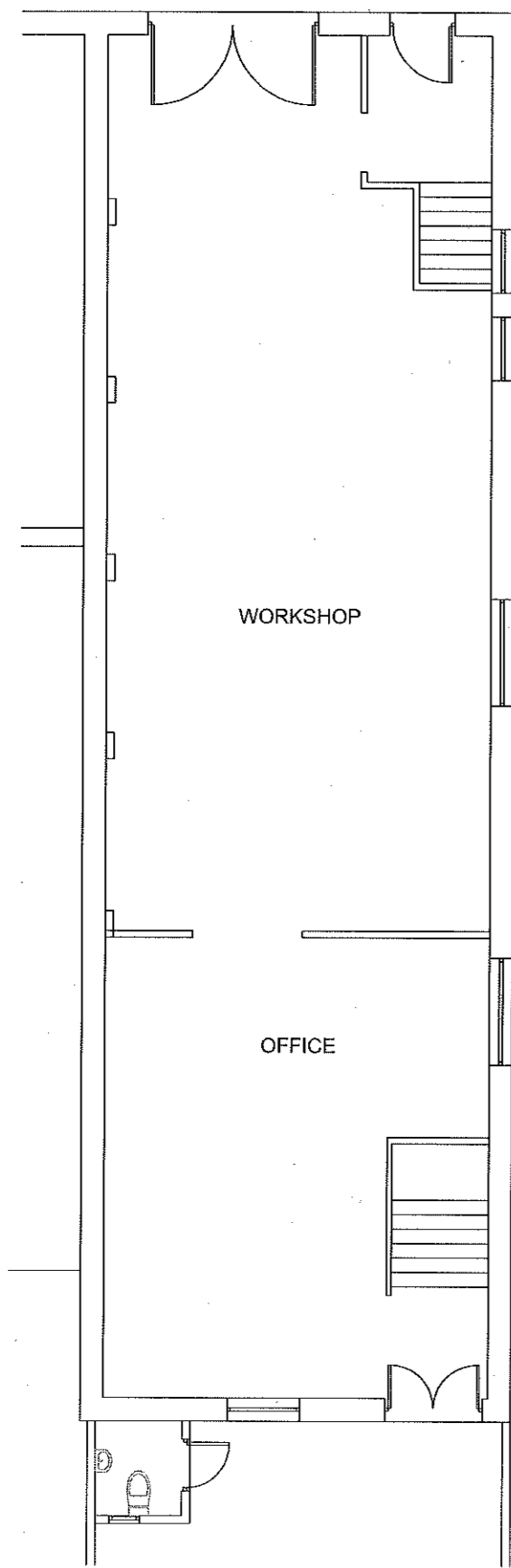

EXISTING GROUND FLOOR PLAN

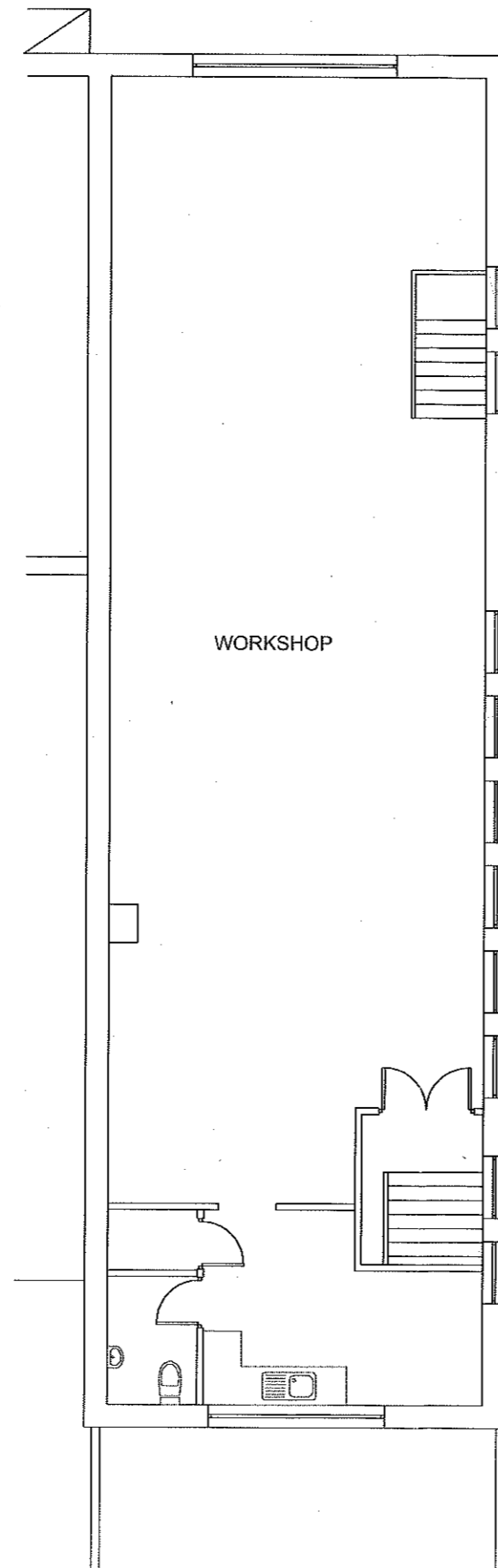

EXISTING FIRST FLOOR PLAN



EXISTING FRONT ELEVATION



3 - BS14 0AJ
 Mob: 07904 980964 Email: redeem.1@hotmail.co.uk

Client A ASHRIF
 105 MINA ROAD ST WERBURGHS BRISTOL

Project
 9 MINTO ROAD ST WERBURGHS BRISTOL

Title CHANGE OF USE FROM INDUSTRIAL UNIT
 TO SINGLE FAMILY DWELLING
 (AMENDMENT TO PLANNING APPROVAL)

Date
 23/06/11

Scale
 1:100

Drg No.
 R112/01

Rev
 D

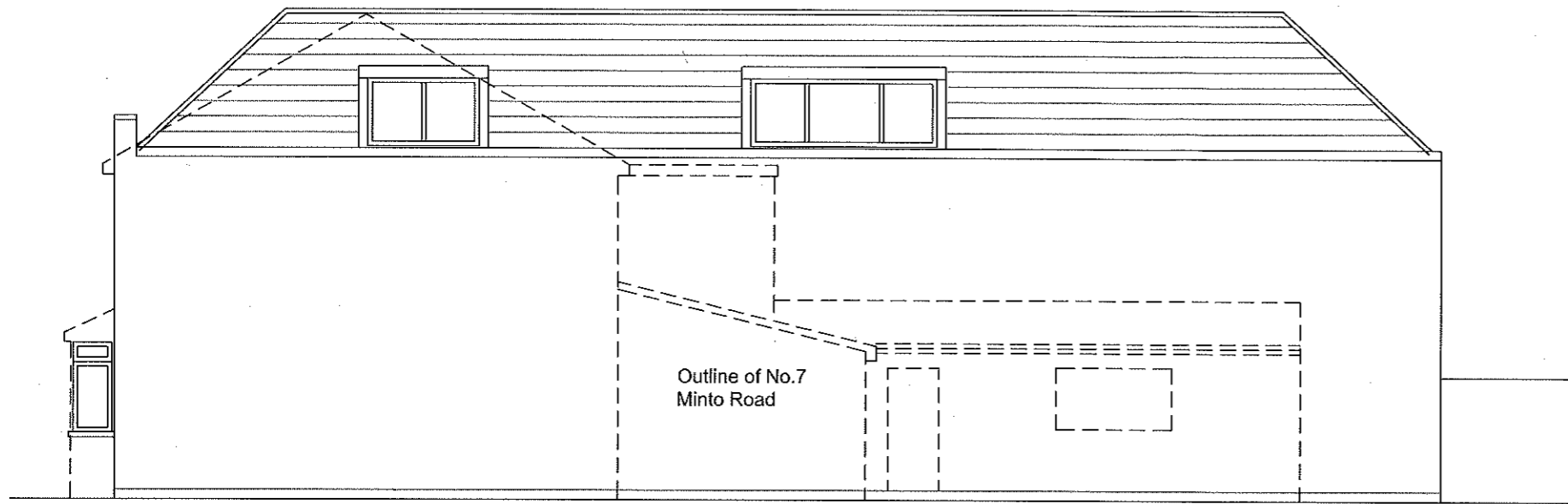

EXISTING SIDE ELEVATION



EXISTING REAR ELEVATION

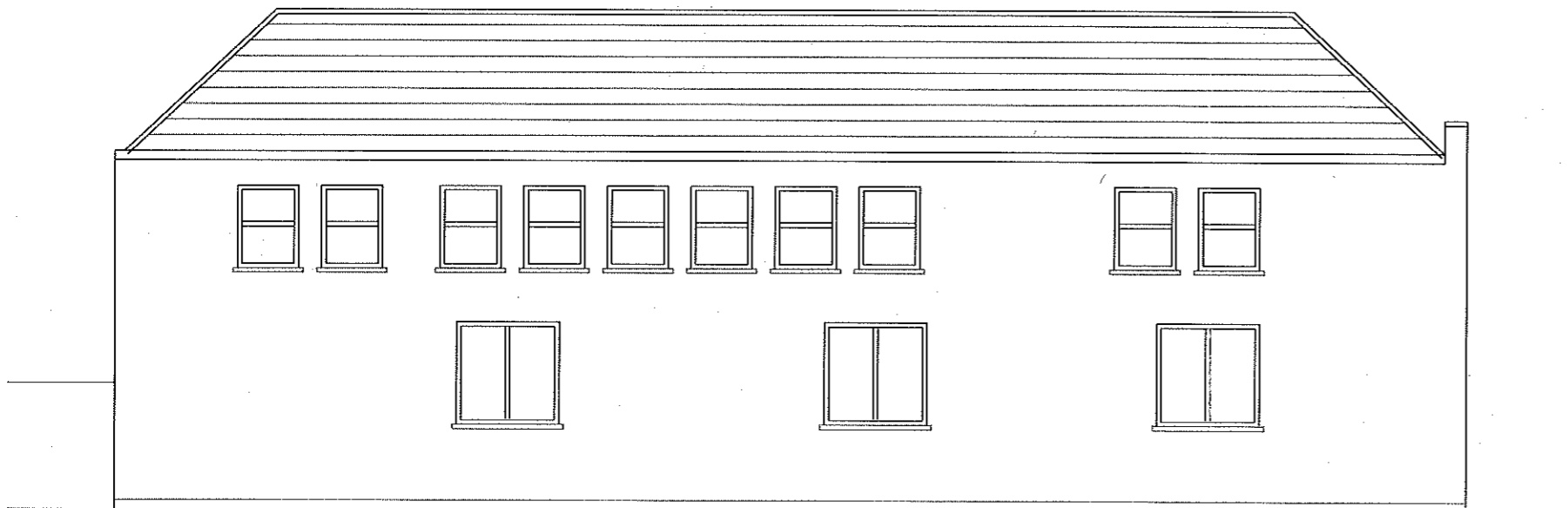

EXISTING SIDE ELEVATION



3 - BS14 0AJ
 Mob: 07904 980964 Email: redeem.1@hotmail.co.uk

Client A ASHRIF
 105 MINA ROAD ST WERBURGHS BRISTOL

Project
 9 MINTO ROAD ST WERBURGHS BRISTOL

Title CHANGE OF USE FROM INDUSTRIAL UNIT
 TO SINGLE FAMILY DWELLING
 (AMENDMENT TO PLANNING APPROVAL)

Date 23/06/11	Scale 1:100
------------------	----------------

Drg No. R112/02	Rev E
--------------------	----------

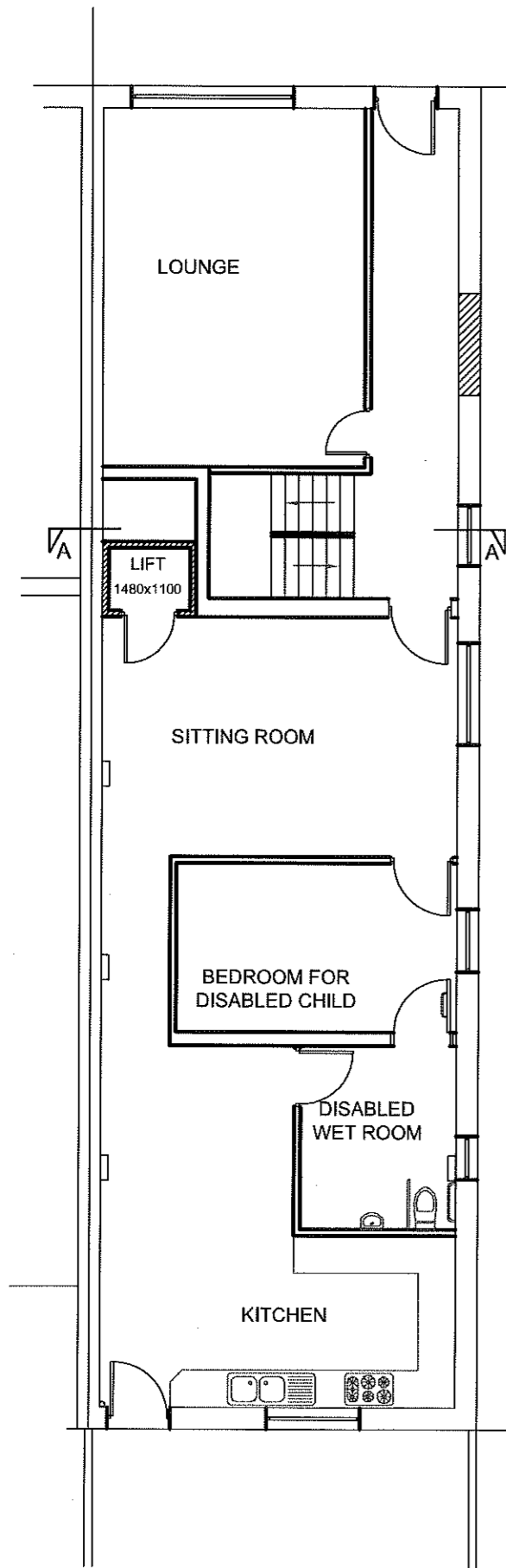

PROPOSED GROUND FLOOR PLAN

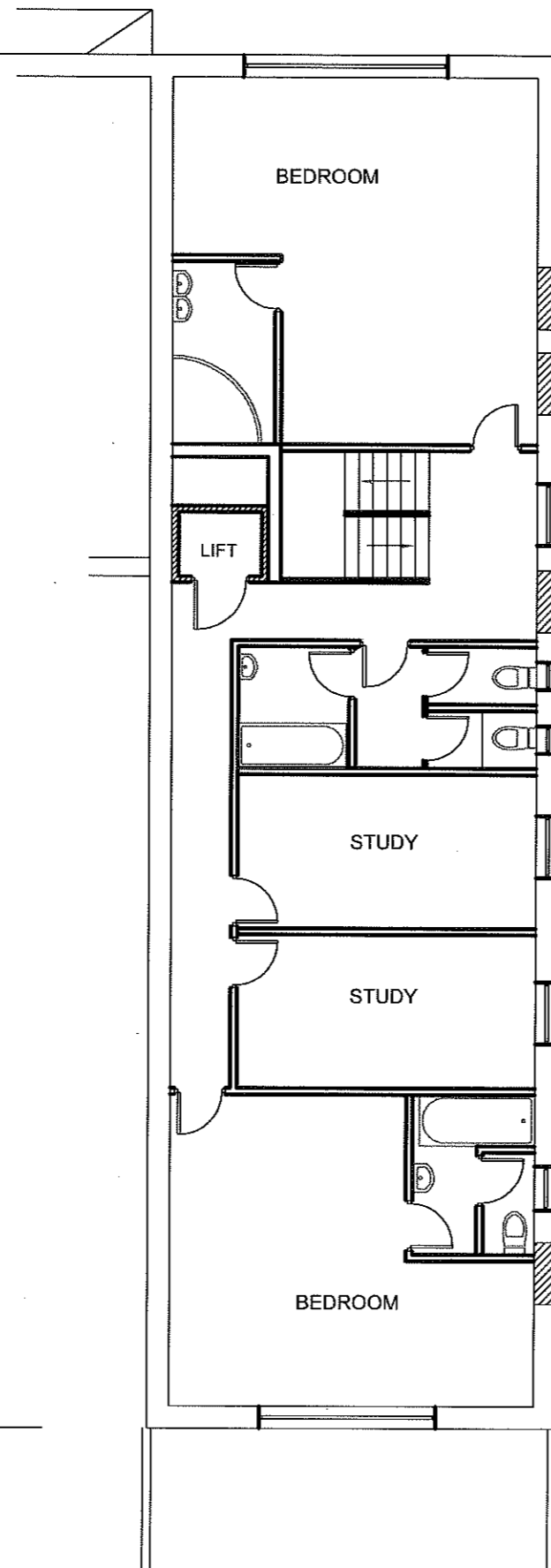

PROPOSED FIRST FLOOR PLAN

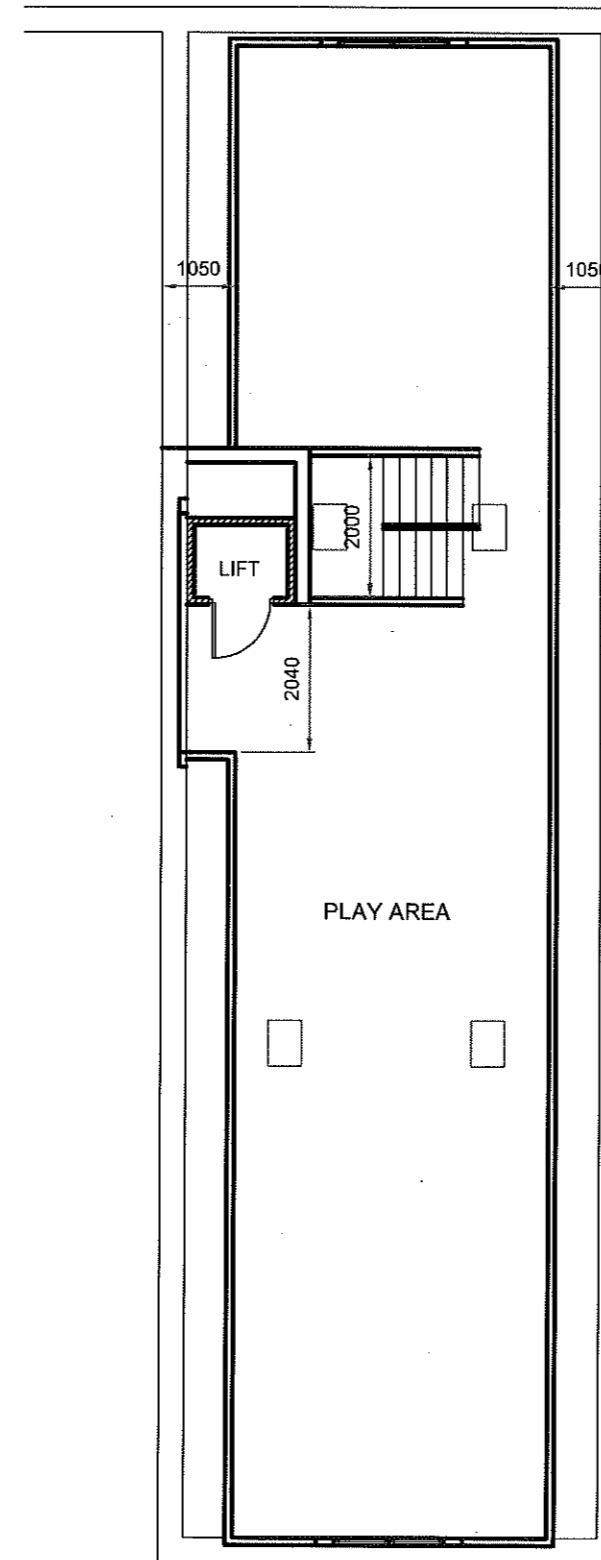

PROPOSED SECOND FLOOR PLAN



3 - BS14 0AJ
 Mob: 07904 980964 Email: redeem.1@hotmail.co.uk

Client A ASHRIF
 105 MINA ROAD ST WERBURGHS BRISTOL

Project
 9 MINTO ROAD ST WERBURGHS BRISTOL

Title CHANGE OF USE FROM INDUSTRIAL UNIT
 TO SINGLE FAMILY DWELLING
 (AMENDMENT TO PLANNING APPROVAL)

Date
 23/06/11

Scale
 1:100

Drg No.
 R112/03

Rev
 F

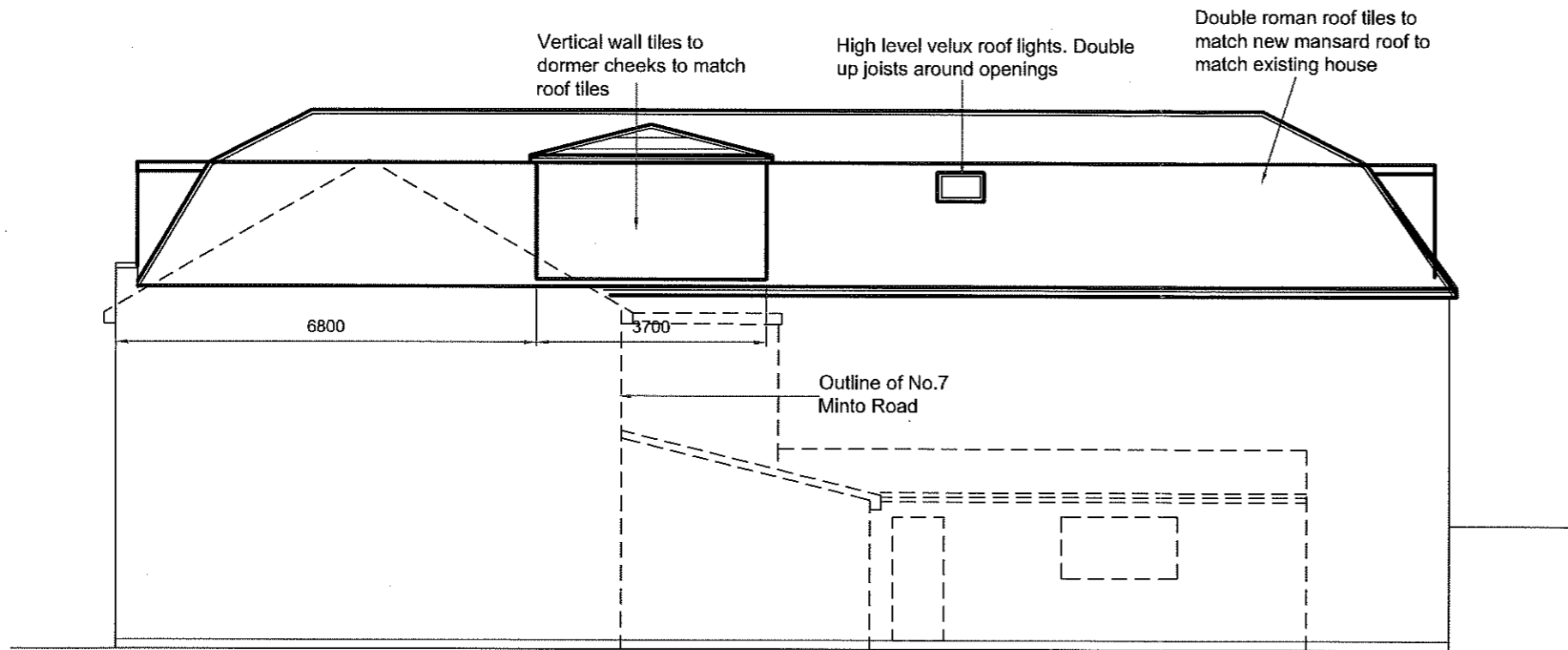

PROPOSED SIDE ELEVATION

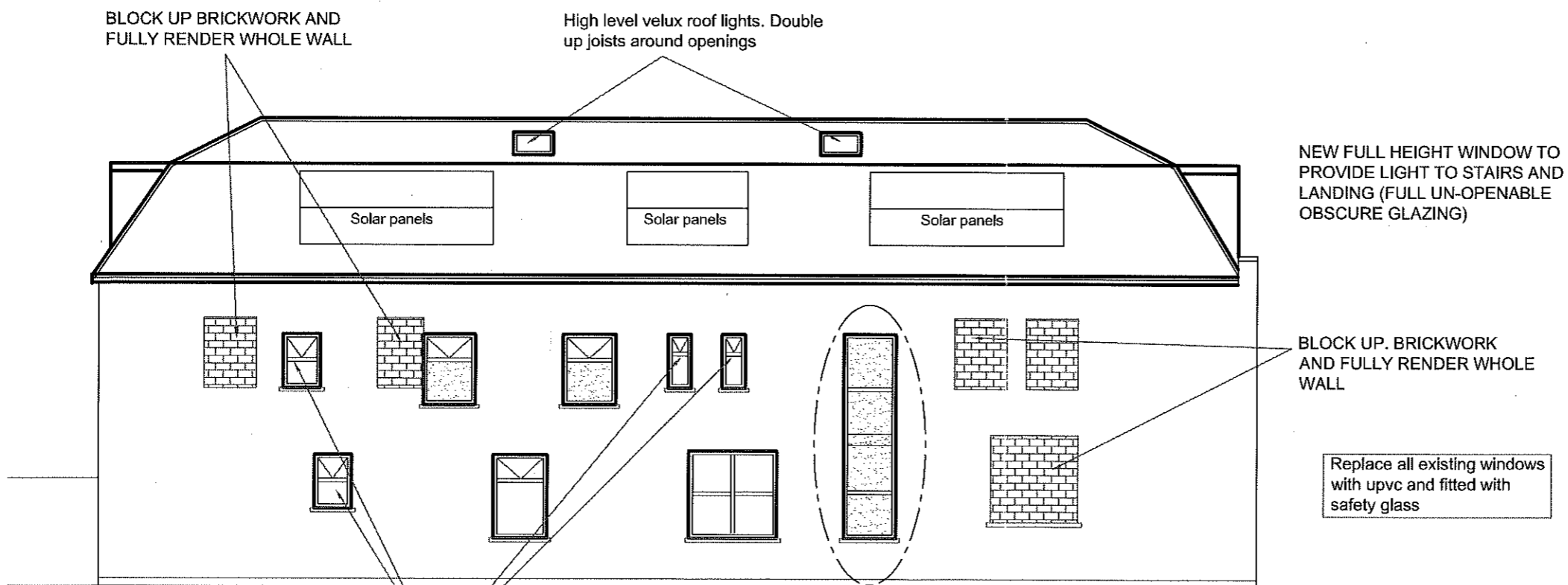

New windows to bathrooms fitted with obscure glazing

PROPOSED SIDE ELEVATION

NOTE
EXISTING WALL TO BE RENDERED TO ENHANCE THE APPEARANCE AND PROTECT THE WALL FROM FURTHER DECAY

ALL REMAINING FIRST FLOOR SIDE WINDOWS TO HAVE OBSCURE GLAZING



3 - BS14 0AJ
Mob: 07904 980964 Email: redeem.1@hotmail.co.uk

Client A ASHRIF
105 MINA ROAD ST WERBURGHS BRISTOL

Project
9 MINTO ROAD ST WERBURGHS BRISTOL

Title CHANGE OF USE FROM INDUSTRIAL UNIT TO SINGLE FAMILY DWELLING (AMENDMENT TO PLANNING APPROVAL)

Date
23/06/11

Scale
1:100

Drg No.
R112/04

Rev
K



Timber barn style double doors
Painted timber facing to match existing

PROPOSED FRONT ELEVATION



ALL REPLACEMENT WINDOWS TO BE UPVC AND FITTED WITH SAFETY GLAZING

PROPOSED REAR ELEVATION

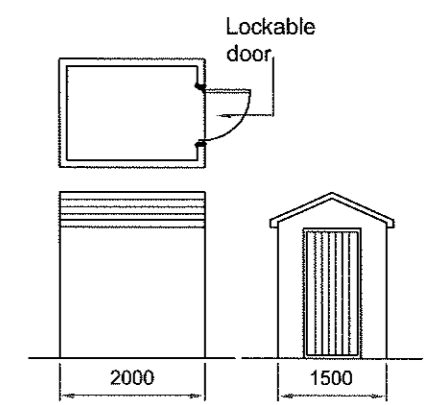

TIMBER CYCLE SHED DETAIL



SITE LOCATION PLAN 1:1250

 <p>3 - BS14 0AJ Mob: 07904 980964 Email: redeem.1@hotmail.co.uk</p>	
Client	
A ASHRIF 105 MINA ROAD ST WERBURGHS BRISTOL	
Project	
9 MINTO ROAD ST WERBURGHS BRISTOL	
Title	
CHANGE OF USE FROM INDUSTRIAL UNIT TO SINGLE FAMILY DWELLING (AMENDMENT TO PLANNING APPROVAL)	
Date	Scale
23/06/11	1:100, 1:1250
Drg No.	Rev
R112/05	I



EXISTING BLOCK PLAN 1:200

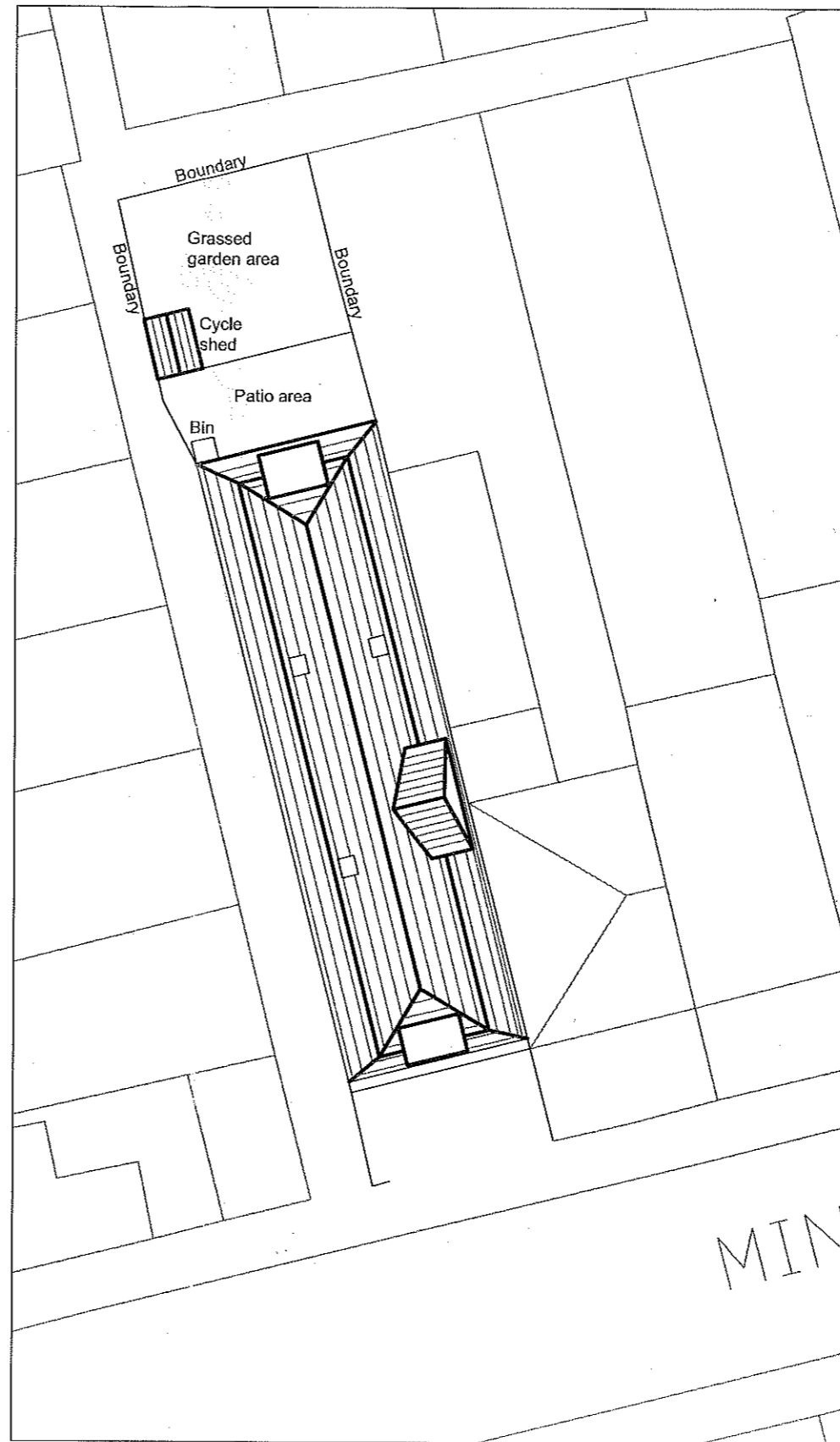

PROPOSED BLOCK PLAN 1:200



3 - BS14 0AJ
 Mob: 07904 980964 Email: redeem.1@hotmail.co.uk

Client A ASHRIF
 105 MINA ROAD ST WERBURGHS BRISTOL

Project
 9 MINTO ROAD ST WERBURGHS BRISTOL

Title CHANGE OF USE FROM INDUSTRIAL UNIT
 TO SINGLE FAMILY DWELLING
 (AMENDMENT TO PLANNING APPROVAL)

Date 23/06/11 Scale 1:200

Drg No. R112/06 Rev F

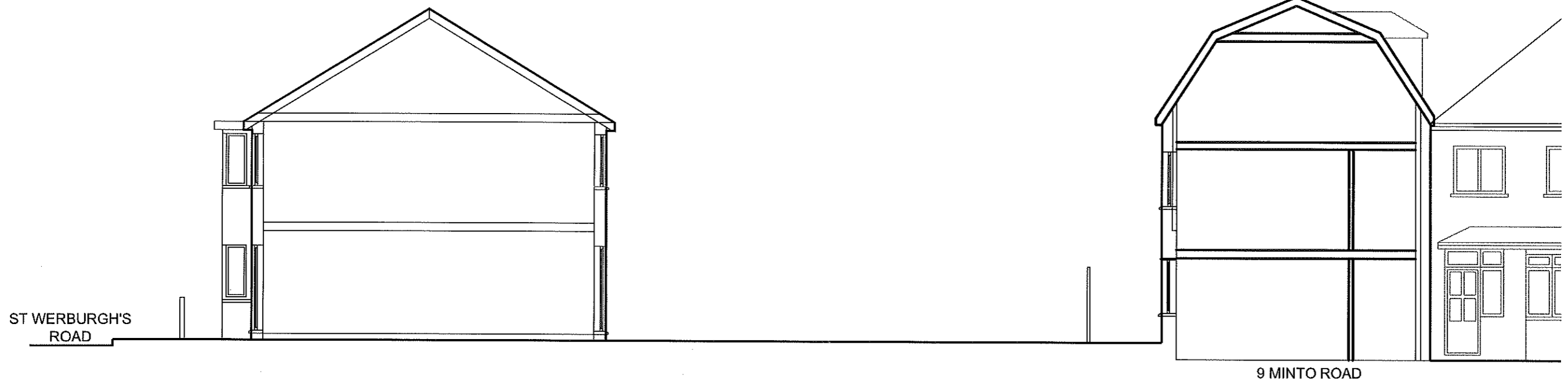

SECTION SHOWING RELATIONSHIP BETWEEN
DEVELOPMENT AND HOUSES ON ST WERBURGH'S ROAD



3 - BS14 0AJ
Mob: 07904 980964 Email: redeem.1@hotmail.co.uk

Client A ASHRIF
105 MINA ROAD ST WERBURGHS BRISTOL

Project
9 MINTO ROAD ST WERBURGHS BRISTOL

Title CHANGE OF USE FROM INDUSTRIAL UNIT
TO SINGLE FAMILY DWELLING
(AMENDMENT TO PLANNING APPROVAL)

Date 24/02/14	Scale 1:100 @ A3
------------------	---------------------

Drg No. R112/07	Rev C
--------------------	----------